

合金钢; 与F266-1承压头配套安装

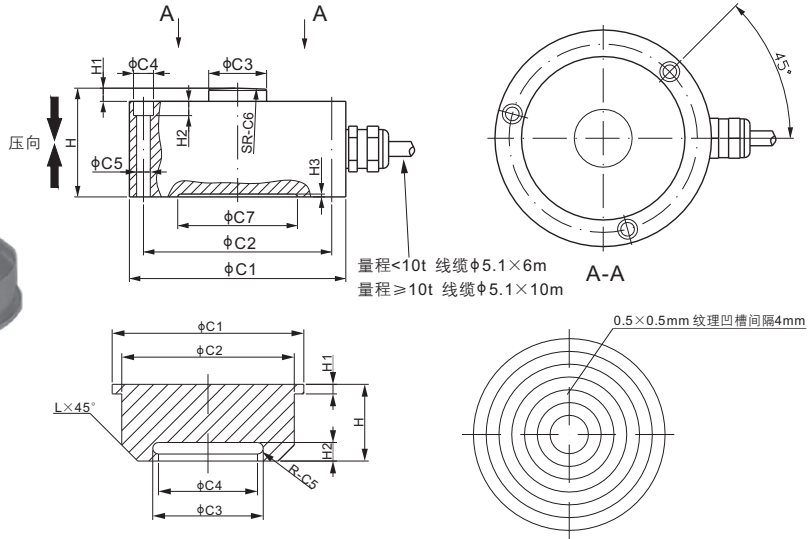

CE Ex ATEX FM APPROVED IECEx RoHS
标配含压头, 无需单独订购。

尺寸

量程	C1	C2	C3	C4	C5	C6	C7	H	H1	H2	H3
t/mm											
5	60.0	52.0	9.5	6.0	3.2	30.0	42.0	24.0	4.0	3.0	0.8
10	63.6	55.0	13.5	7.2	4.2	100.0	44.0	26.0	4.0	5.0	0.8
25	75.9	66.0	20.3	7.0	4.8	150.0	54.0	38.1	4.6	5.0	1.0
50	105.0	90.0	30.0	11.0	6.5	250.0	76.0	53.0	7.0	7.0	1.0
100	123.0	98.0	43.0	15.0	10.5	380.0	74.0	95.0	15.0	12.0	1.0
lb/inches (由上述尺寸转换)											
11,023.1	2.36	2.05	0.37	0.24	0.13	1.18	1.65	0.94	0.16	0.11	0.03
22,046.2	2.50	2.17	0.53	0.28	0.17	3.94	1.73	1.02	0.16	0.20	0.03
55,115.6	2.99	2.60	0.80	0.28	0.19	5.91	2.13	1.50	0.18	0.20	0.04
110,231.1	4.13	3.54	1.18	0.43	0.28	9.84	2.99	2.09	0.28	0.28	0.04
220,462.3	4.84	3.86	1.69	0.59	0.41	14.96	2.92	3.74	0.59	0.47	0.04
货号	传感器量程	C1	C2	C3	C4	C5	H	H1	H2	L	毛重(kg)
t/mm											
F266-1A	5	33.0	27.0	12.0	10.0	1.0	13.0	3.0	2.9	3.0	0.06
F266-1B	10	41.0	35.0	16.0	14.0	1.0	16.0	3.0	2.9	4.0	0.12
F266-1C	25	49.0	43.0	23.8	21.0	1.4	19.0	3.0	3.9	5.0	0.20
F266-1E	50	72.0	66.0	34.6	31.0	1.8	36.0	3.0	5.7	5.0	-
F266-1F	100	80.0	74.0	55.0	45.0	5.0	50.0	3.0	12.4	7.0	-
lb/inches (由上述尺寸转换)											
F266-1A	11,023.1	1.30	1.06	0.47	0.39	0.04	0.51	0.12	0.11	0.12	0.06
F266-1B	22,046.2	1.61	1.38	0.63	0.55	0.04	0.63	0.12	0.11	0.16	0.12
F266-1C	55,115.6	1.93	1.69	0.94	0.83	0.06	0.75	0.12	0.15	0.20	0.20
F266-1E	110,231.1	2.83	2.60	1.36	1.22	0.07	1.42	0.12	0.22	0.20	-
F266-1F	220,462.3	3.15	2.91	2.17	1.77	0.20	1.97	0.12	0.49	0.28	-

技术参数

灵敏度	2.5 mV/V ± 10%	额定激励电压	10V (15V 最大)
零位输出	±0.02 mV/V	绝缘阻抗	>2 [50V DC] GΩ
非线性	量程 ≤ 50t: < ±0.32%; 量程 ≥ 100t: < ±1%	正常工作温度范围	-10°C - 50°C / 14°F - 122°F
重复性	量程 ≤ 50t: < ±0.050%; 量程 ≥ 100t: < ±0.2%	安全极限载荷	150% 满量程
滞后误差	量程 ≤ 50t: < ±0.32%; 量程 ≥ 100t: < ±2%	破坏极限载荷	300% 满量程
蠕变	量程 ≤ 50t: < ±0.10%; 量程 ≥ 100t: < ±0.1%	密封方式	密封 / IP67
输入阻抗	400Ω ± 20	接线方式	Exc+ 红 Exc- 黑 Sig+ 绿 Sig- 白 屏蔽线
输出阻抗	350Ω ± 3		
原材料	合金钢		

货号*

量程	货号	毛重(kg)
5t	276EH-5t	0.6
10t	276EH-10t	0.9
25t	276EH-25t	1.8
50t	276EH-50t	4.2
100t	276EH-100t	8.7

可配套模块

型号	页码
276EHM1	139

* ATEX, FM, IECEx 认证版本货号带有“-Ex”后缀