

不锈钢

量程：50-500lb

量程：1-20Klb

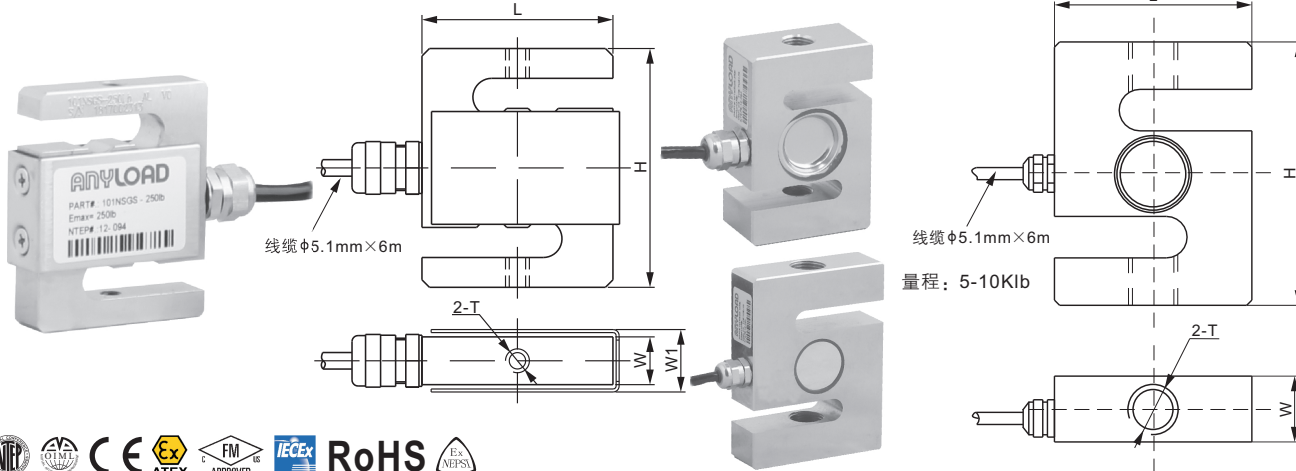

尺寸

量程	H	L	W	W1	T
lb/inches					
50-250	2.50	2.00	0.50	0.65	1/4-28 UNF-2B
500	3.00	2.00	0.75	0.89	1/2-20 UNF-2B
1,000-3,000	3.00	2.00	1.11	-	1/2-20 UNF-2B
5,000; 10,000	4.00	3.00	1.00	-	3/4-16 UNF-2B
15,000	5.50	4.00	1.25	-	1-14 UNS-2B
20,000	7.00	5.00	2.00	-	1 1/4-12 UNF-2B
kg/mm (由上述尺寸转换)					
22.68-113.4	63.5	50.8	12.7	16.6	1/4-28 UNF-2B
226.8	76.2	50.8	19.1	22.6	1/2-20 UNF-2B
453.6-1,360.8	76.2	50.8	28.2	-	1/2-20 UNF-2B
2,268; 4,535.9	101.6	76.2	25.4	-	3/4-16 UNF-2B
6,803.9	139.7	101.6	31.8	-	1-14 UNS-2B
9,071.8	177.8	127.0	50.8	-	1 1/4-12 UNF-2B

技术参数

灵敏度	3.0 mV/V ± 1%	额定激励电压	10V (15V 最大)
零位输出	±0.02 mV/V	绝缘阻抗	>2 [50V DC] GΩ
非线性	<±0.017%	正常工作温度范围	-10°C - 50°C / 14°F - 122°F
重复性	<±0.017%	安全极限载荷	150% 满量程
滞后误差	<±0.017%	破坏极限载荷	300% 满量程
蠕变	<±0.023%	密封方式	量程 ≤ 500lb: 密封 / IP66 量程 ≥ 1Klb: 密封 / IP67
输入阻抗	350Ω ± 7	接线方式	Exc+ 红 Exc- 黑
输出阻抗	350Ω ± 3		Sig+ 绿 Sig- 白 屏蔽线
原材料	17-4PH 不锈钢		

货号*

量程	形变量(inch)	货号	毛重(lb)
50lb	-	101NSGS-50lb	1.1
100lb	-	101NSGS-100lb	1.1
250lb	-	101NSGS-250lb	1.1
500lb	-	101NSGS-500lb	1.5
1Klb	0.003-0.007	101NSGS-1Klb	1.8
1.5Klb	-	101NSGS-1.5Klb	1.8
2Klb	-	101NSGS-2Klb	1.8
2.5Klb	-	101NSGS-2.5Klb	1.8
3Klb	-	101NSGS-3Klb	1.8
5Klb	-	101NSGS-5Klb	2.9
10Klb	-	101NSGS-10Klb	2.9
15Klb	-	101NSGS-15Klb	6.6
20Klb	-	101NSGS-20Klb	15.0

可互换产品

制造商	型号
Coti Global	CGSB-SS
Rice Lake	RL20000 SS
Rice Lake	RL20000 ST
Vishay Celtron	STC-SS
Vishay Revere Transducers	9363
Vishay Sensortronics	60050

100lb-500lb: NTEP 1:4 500 Class III, Single Cell;
 1Klb-20Klb: NTEP 1:5 500 Class III, Single Cell
 200kg-1.5t: OIML MAA C3, Y=17 000;
 2t-10t: OIML MAA C4.5, Y=14 000

* ATEX, FM, IECEx 认证版本货号带有 "-Ex" 后缀

www.anyload.com.cn

© 第23版 ANYLOAD V3 产品尺寸及规格更改, 恕不另行通知